

RSTEEL[®]



RPK-N3

Column Shoe

Technical manual

Version: 21.04.2026

All rights reserved.



Index

1. DESCRIPTION OF THE SYSTEM	3
2. MATERIALS AND DIMENSIONS	4
3. MANUFACTURING	5
3.1. Manufacturing method	5
3.2. Surface treatment	5
3.3. Quality control	5
3.4. Markings	5
4. RESISTANCES	6
5. USER INSTRUCTIONS	7
5.1. Limits of use	7
5.2. Design guidance	7
5.2.1. Shear resistance	7
5.2.2. Resistance due to friction	7
5.2.3. Bolt shear resistance	7
5.2.4. Design criteria	8
5.3. RPP base bolt design resistances	8
5.4. Fire design	10
5.5. Column reinforcement instructions	11
6. INSTALLATION	13
6.1. At the factory	13
6.2. Installation of the column	14
6.2.1. Installation accessories for recess	14
6.2.2. Installation accessories for shoe positioning	18
TECHNICAL MANUAL REVISIONS	20
SUPPORT MATERIAL	21

1. DESCRIPTION OF THE SYSTEM

Column shoes are fastening components that are used to create moment resisting connections for precast columns. Stresses developed within the column are transferred to the column shoes, through the anchor bolts and across the grouted gap, to the adjoined structures e.g. to the foundations.

It is possible to adjust the vertical position and level of the column using the column shoes. The gap that remains between the base of the column and the top of the adjoined structure is grouted up as soon as possible after the connection is set. The base connection, once grouted, is designed to be stronger than the cross-section of the column.

Column shoes bring following benefits during the construction process:

- ✓ Simple connection by bolting members together
- ✓ Faster erection and easily adjustable connection
- ✓ Immediate transfer of erection forces once the column is erected and bolted
- ✓ No additional support or temporary bracing system required

2. MATERIALS AND DIMENSIONS

Table 1. Materials and standards of RPK-N3 column shoes

Part	Material	Standard
Plates	S355J2	EN 10025
	S355J2+N	EN 10025
Rebars	B500B	EN 10080 (SFS 1300)

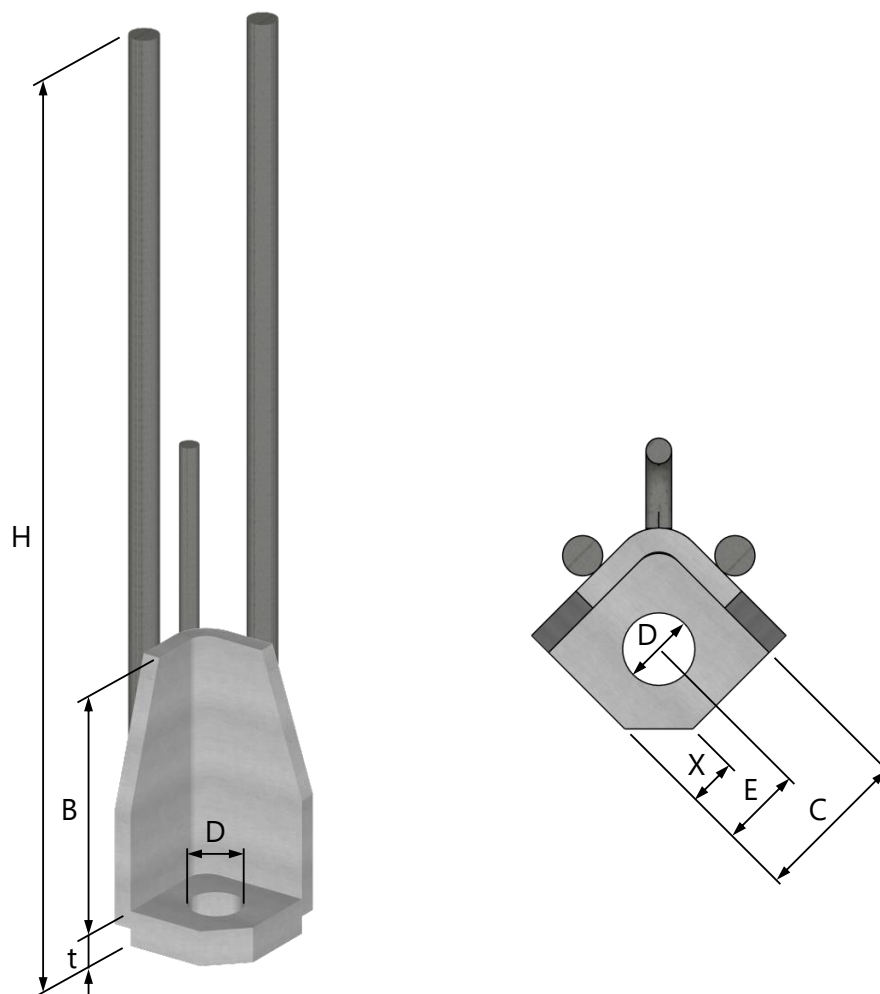

Figure 1. Dimension markings of RPK-N3 column shoes

Table 2. Dimensions of RPK-N3 column shoes

RPK-N3	B [mm] +3/-0	C [mm] +2/-0	E [mm] ±1	H [mm] +0/-10	t [mm]	D [mm] +2/-0	X [mm]	Main bars	Weight	Color
M16	102	80	50	597	15	28	30	2×Ø12	2.4	Yellow
M20	100	83	50	820	20	31	30	2×Ø16	4.3	Blue
M24	120	90	50	1185	30	35	30	2×Ø16	6.5	Grey
M30	130	95	50	1390	45	40	30	2×Ø20	11.5	Green
M39	210	120	60	1910	50	55	37	3×Ø25	25.5	Orange

3. MANUFACTURING

3.1. Manufacturing method

Plates:	Thermal or mechanical cutting
Rebars:	Mechanical cutting
Welding:	MAG welding, manual or robotic
Welding class:	B (EN ISO 5817)
Execution class:	EXC2 (EN 1090-2) [more demanding classes according to a separate guideline]
Surface treatment:	Untreated as standard



The product shall be produced clean and dry. Light surface rusting may be present at delivery of the product. The product is to be stored in dry conditions. The product may be installed with light surface rusting, and in accordance with general requirements for rebars.

3.2. Surface treatment

RPK-N3 column shoes come with no surface treatment. Upon request the column shoes can be delivered hot dip galvanized according to galvanizing standard.

3.3. Quality control

R-Group Baltic OÜ internal manufacturing and quality control in accordance with EN 1090-2. External quality control provided to R-Group Baltic OÜ by Kiwa Inspecta OÜ.

3.4. Markings

RPK-N3 column shoes are marked with at least the RSTEEL® logo, type and identifier, manufacturing date, FI and BY (Concrete Association of Finland) logo.

4. RESISTANCES

The tension resistance of the column shoe, calculated in accordance with Eurocodes (EN 1992 and EN 1993), is governed by the tension resistance of the connected RPP base bolt. More information is provided in RPP base bolt technical manual.

The minimum concrete grade of the column is C30/37. Normal material partial factors for resistance and normal production tolerances have been used for determining the length of main reinforcement bars for lapping.

The anchorage length (lap length) is determined based on the diameter of the anchor.

Anchorage coefficients, lap factor $\alpha_6 = 1.5$, $\alpha_2 = 0.7$ and $\alpha_1... \alpha_5 = 1.0$.

Table 3. Nominal design tension resistances of RPK-N3 column shoes

RPK-N3	RPP	N_{Rd} [kN]
M16	M16	62.2
M20	M20	97.0
M24	M24	139.4
M30	M30	222.2
M39	M39	386.5

The shear capacity of the shoe is governed by the connected RPP base bolt.



RSTEEL® Design Tool software for bolted connections on [rsteel-design.com](https://www.rsteel-design.com).

Column connection rotational stiffness is covered by EOTA European Assessment Document DP 17-20-0102-03.02 (March 2018). When designing the column (EN 1992-1-1 figure 5.7), connection rotational stiffness parameter k_L is to be considered in accordance with section 3.4 of EOTA Technical Report 068 (September 2018 A: March 2020).

When RPK-N3 column shoes are used for forming the column connection, parameter k_L is equal to 1.0, and the column connection can be considered to be moment rigid. Column shoe installation and additional reinforcement must be in accordance with instructions in this user guide.

5. USER INSTRUCTIONS

5.1. Limits of use

The capacities of the column shoes have been calculated for static loads. Increased load factors are to be adopted for case specific dynamic and fatigue effects. For design in accordance with the Eurocodes, the lowest operating temperature is calculated from EN 1991-1-5.

5.2. Design guidance

The shear strength of the connection can be calculated in accordance with EN 1993-1-8 clause 6.2.2. The additional contribution of friction to shear strength can be taken into account; a friction coefficient of 0.2 can be adopted for a sand-cement grout, without additional tests.

5.2.1. Shear resistance

$$V_{Rd} = F_{f,Rd} + n \cdot F_{vb,Rd}$$

where n is the number of bolts on the compression side of the column.

5.2.2. Resistance due to friction

$$F_{f,Rd} = C_{f,d} \cdot N_{c,Ed}$$

where $C_{f,d}$ is 0.2 and $N_{c,Ed}$ = the axial compression applied by the column.

5.2.3. Bolt shear resistance

$$F_{vb,Rd} = \min \{F_{1,vb,Rd}; F_{2,vb,Rd}\}$$

$$F_{1,vb,Rd} = (k_1 \cdot \alpha_b \cdot f_{base,u} \cdot d_b \cdot t_{base}) / \gamma_{M2}$$

$$F_{2,vb,Rd} = (\alpha_{bc} \cdot f_{bolt,u} \cdot A_{bolt}) / \gamma_{M2}$$

k_1 and α_b according to EN 1993-1-8, Table 3.4

$$\alpha_{bc} = 0.44 - 0.0003 \cdot f_{bolt,y}$$

$f_{bolt,y}$ is the yield strength of the base bolt, where $f_{bolt,y} \leq 640 \text{ N/mm}^2$

$f_{base,u}$ and $f_{bolt,u}$ are the base plate and the bolt ultimate tensile strengths respectively

A_{bolt} is the net tensile area of the base bolt

γ_{M2} is the material partial factor for resistance, EN 1993-1-8, Table 2.1

5.2.4. Design criteria

$$V_{Ed} \leq V_{Rd}$$

$$N_{Ed} \leq N_{Rd}$$

$$N_{Ed}^1 / 1.4N_{Rd} + V_{Ed}^1 / V_{Rd} \leq 1$$

Where N_{Ed}^1 and V_{Ed}^1 are applied coincident axial force and shear force.

Shear strength during erection, governed by the shear transfer capability of the base bolt, can be calculated using EOTA TR-068: 2020. Shear strength values calculated in accordance with EN 1992-4:2018 are provided in Table 4 in brackets.

5.3. RPP base bolt design resistances

Table 4. Design resistances of RPP base bolts

RPP	Tension N_{Rd} [kN]	Shear $V_{Rd,u}$ [kN]	Net tensile area A [mm ²]	Lever arm t_R [mm]
M16	62.2	7.5 (4.5) ¹	157	37 (65) ¹
M20	97.0	15.1 (8.3) ¹	245	36 (69) ¹
M24	139.4	27.1 (13.0) ¹	352	34 (76) ¹
M30	222.2	60.3 (23.0) ¹	561	31 (86) ¹
M39	386.5	120 (44.3) ¹	976	36 (103) ¹



Shear resistance during installation and prior to grouting of the base.

(...)¹ → $V_{Rd,u}$ values in brackets are calculated according to EN 1992-4:2018

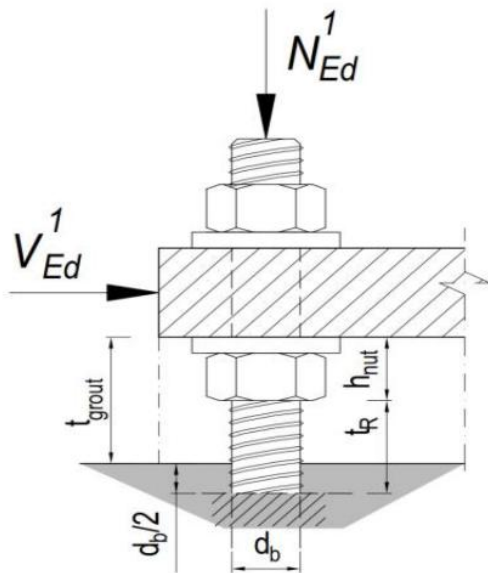

EN 1993-1-8

$$N_{Rd} = 0.9f_{uk} \cdot A / \gamma_{Ms}$$

$$\gamma_{Ms} = 1.25 \text{ and } f_{uk} = 550 \text{ MPa}$$

EOTA TR 068: 2020 (3.3.2)

$$16V_{Ed} \cdot t_r / \pi d^3 + 4N_{Ed} / \pi d^2 \leq f_{bolt,y}$$

($N_{Ed} = 0$; shear only)

$$V_{Ed} \leq f_{bolt,y} \cdot \pi d^3 / 16t_r$$

$$V_{Rd,u} \leq f_{bolt,y} \cdot \pi d^3 / 16t_r$$

$$f_{bolt,y} = 500 \text{ MPa}$$

Moment lever arm is calculated in accordance with base grout thickness presented in Table 9.

The base is to be grouted as soon as possible following installation and setting of the column. Following hardening of the grout, structures can be added to the top or corbel of the column. The strength of the grout used (in the base joint as well as to fill the box of the shoe) is to be at least as strong as the design strength of the concrete of the connecting column. Cement grout must be non-shrink (zero shrinkage). Instructions provided by the grout manufacturer and by the designer must be followed.

In the erection case, base bolts are verified against applied wind loads and dead load. Additional wind load from column corbels must be taken into account.

Nominal concrete cover is to be in accordance with guidance presented in EN 1992-1-1.

When RPK-N3 shoe is positioned in the column formwork using the casting box, the concrete cover to the anchor bars is according to Table 5.

Table 5. Minimum concrete cover

RPK-N3	Concrete cover [mm]
M16	45
M20	45
M24	45
M30	45
M39	45



If greater cover is required, then the shoe is to be positioned deeper into the column.

Table 6. Minimum column sizes for RPK-N3 column shoe

RPK-N3	Rectangular column [mm × mm]	Round column [mm]
M16	230 x 230	285
M20	240 x 240	300
M24	250 x 250	315
M30	280 x 280	360
M39	360 x 360	460



If the required column is smaller than the minimum column size given in the table above, then please contact RSTEEL® technical department at technical@rsteel.eu.

5.4. Fire design

Structural fire design of the column is to be undertaken in accordance with EN 1992-1-2. Fire resistance of R90-R120 can be achieved with the above concrete cover values, following the dimensioning criteria set-out in tabulated data of EN 1992-1-2.

The fire resistance of the base plate of the shoe, without any additional provided fire protection, is R60. For exposure class X0 (dry internal environment) the base plate can be left exposed if the surfaces can be accessed for maintenance of the surface treatment e.g. corrosion protection system and fire protection system. For exposure classes XC, XD and XS, corrosion protection (surface treatment and/or protective concrete cover layer) is to be provided for at least the exposure class and design life of the connected structures. For exposure class XC hot dip galvanization is required. For exposure classes XD as well as XS, in addition to hot dip galvanization, an additional layer of reinforced concrete (that prevents water ingress up to the column shoe) is required.

5.5. Column reinforcement instructions

The reinforcement to the column adjacent to the column shoes is to be in accordance with instructions provided in EN 1992, as well as the following details.

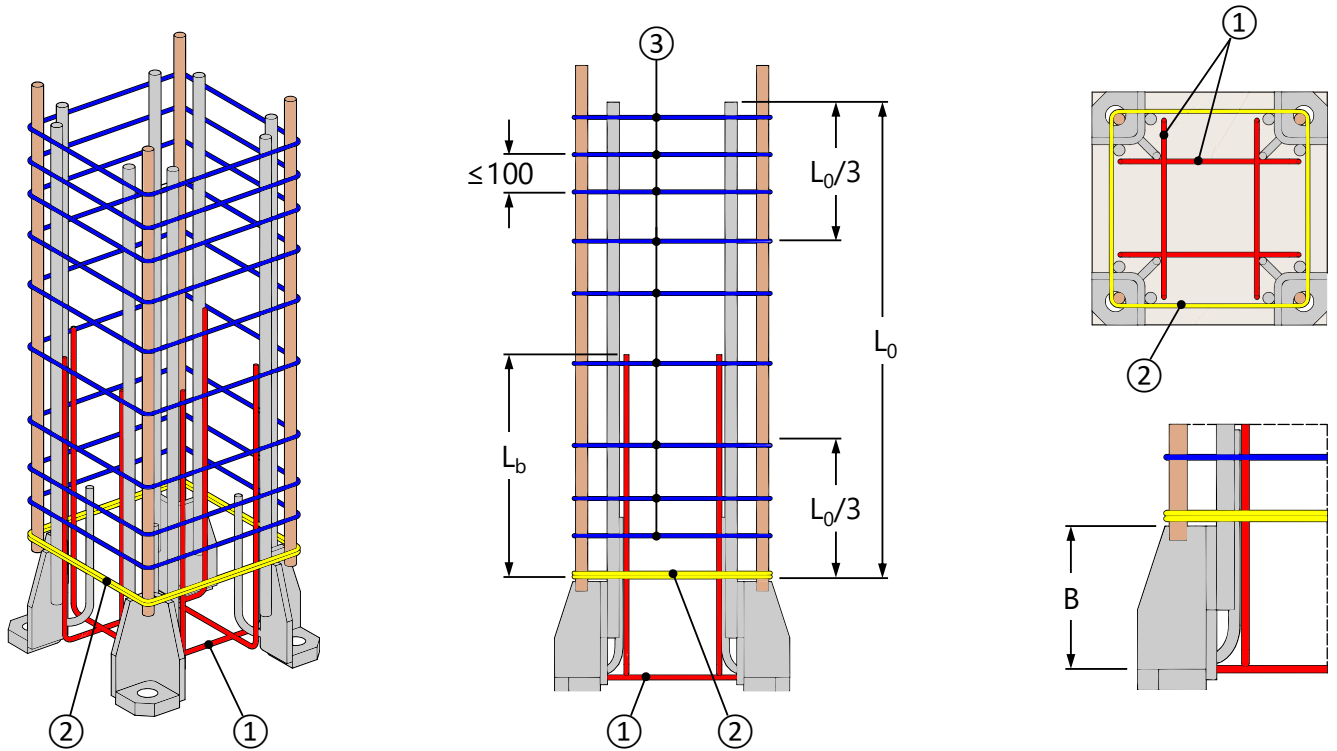

Figure 2. Supplementary reinforcements for square column

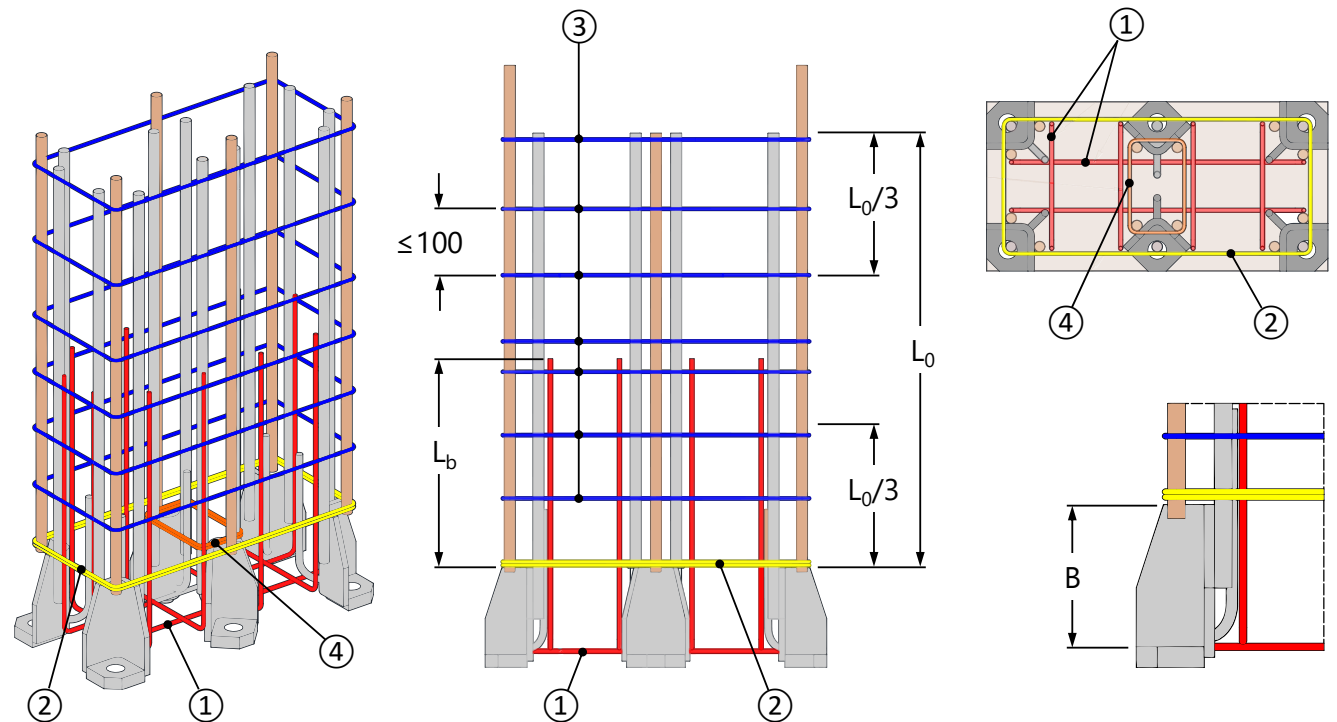

Figure 3. Supplementary reinforcements for rectangular column

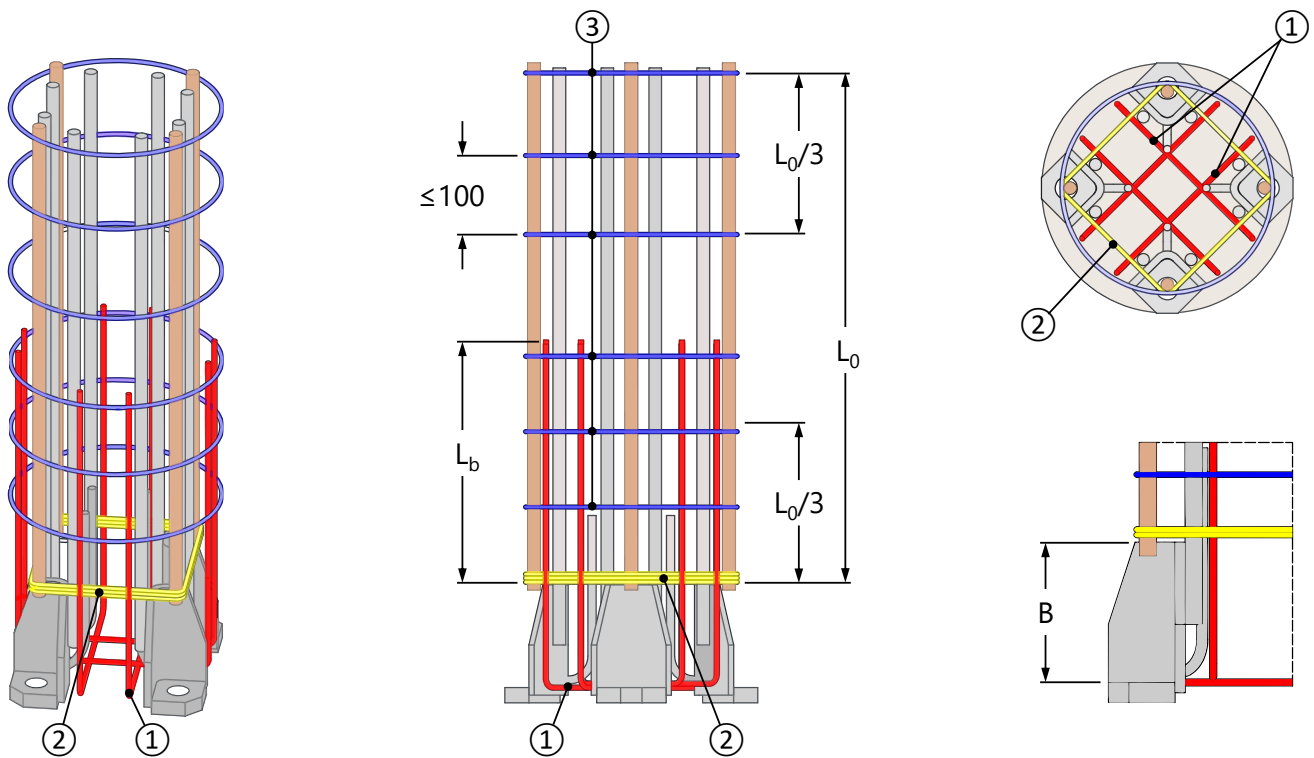

Figure 4. Supplementary reinforcements for round column

Table 7. Supplementary reinforcement for the RPK-N3 column shoe

RPK-N3	U-stirrups ①				Stirrups ②	Stirrups ③	Stirrups ④	Lap zone		Main rebar D_{max} [mm]
	Quantity	\emptyset	L_b [mm]	B [mm]				L_0 [mm]	$L_0/3$ [mm]	
M16	≥ 4	$\emptyset 6$	500	102	$2 \times \emptyset 8$	$\emptyset 8$	$2 \times \emptyset 8$	480	160	20
M20	≥ 4	$\emptyset 6$	500	100	$2 \times \emptyset 8$	$\emptyset 8$	$2 \times \emptyset 8$	700	235	20
M24	≥ 4	$\emptyset 6$	500	120	$3 \times \emptyset 8$	$\emptyset 8$	$3 \times \emptyset 8$	1035	345	25
M30	≥ 4	$\emptyset 6$	500	130	$3 \times \emptyset 8$	$\emptyset 8$	$3 \times \emptyset 8$	1215	405	32
M39	≥ 4	$\emptyset 6$	500	210	$3 \times \emptyset 10$	$\emptyset 8$	$3 \times \emptyset 10$	1650	550	32



Within the zone defined by L_0 , the maximum recommended spacing of stirrups according to EN 1992-1-1 is 100 mm.

Columns with centrally positioned shoes:

Stirrup ①: add 2 pieces of ① stirrups per shoe pair (1 pc to each side of each pair).

Stirrup ④: add ④ stirrups around each shoe pair. Required number of stirrups according to the table.

6. INSTALLATION

The column shoe is tied into the main reinforcement and is connected to the end plate of the formwork by bolting through the base plate.

Table 8. Installation tolerances

RPK-N3	Installation tolerance in cross-section [mm]
M16	±2
M20	±2
M24	±2
M30	±2
M39	±2

6.1. At the factory

Checklist before casting:

- The correct shoe type and size is installed
- The positioning of the shoe is correct and according to installation tolerances
- The shoe is properly secured in the reinforcement and formwork
- The correct supplementary reinforcement is installed according to manufacturing drawings

Checklist after casting:

- The position of the shoe is correct and according to tolerances
- Shoes are cleaned and any casting boxes are removed
- Casting boxes are removed

6.2. Installation of the column

The column is installed at the correct level either by adjusting the nuts to the bolted connection or by using packer plates. Nuts are to be firmly tightened, for example using an impact wrench. Sufficient tightening torque is usually achieved with 10-15 impacts to a slogging ring wrench (DIN 7444) or open-ended slogging wrench (DIN 133) using a 1.5 kg hammer. A gap between the base plate of the column shoe and the nut of the bolt must be avoided. Erection must follow the erection scheme that is approved by the responsible engineer.

Once the column is set at the correct level and inclination, and the nuts are tightened, the base is to be grouted in accordance with the manufacturer's guidance. The grout must be of a non-shrinkage type and with strength greater than the weakest of the concrete structures that are connected with the bolt and shoe assembly. The sides of the grouted joint may be formed vertically, for example with the help of a casting form.

The height positions and position tolerances of the base bolts are given in Section 6.1 of RPP base bolt technical manual.

Table 9. Installation tolerances and available length of the anchor bolts above concrete surface

RPK-N3	RPP	Base grout, [mm]	Length of bolt above concrete surface, [mm]	Bolt installation tolerance, [mm]
M16	M16	50	105	±3
M20	M20	50	115	±3
M24	M24	50	130	±3
M30	M30	50	150	±3
M39	M39	60	180	±3



Tolerance on position of the base bolt group is ±10 mm. Tolerance for height is ±20 mm.

6.2.1. Installation accessories for recess

RSTEEL® offers two options to ensure the necessary recess when installing column shoes in precast columns: recess former or covering plate.

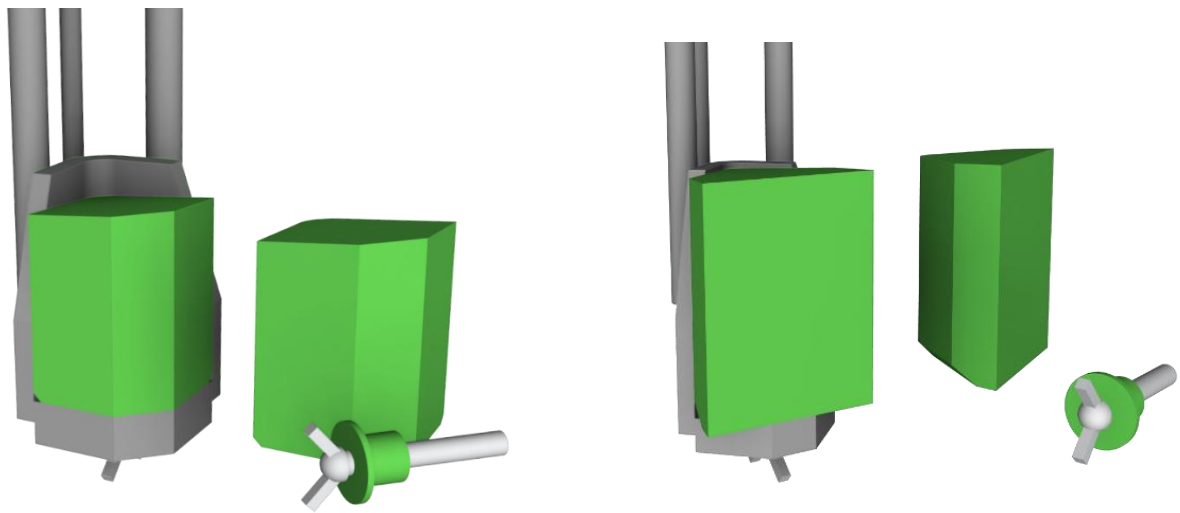

a) Recess former (for corner shoe and middle shoe)

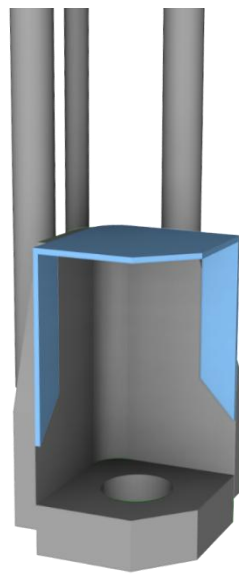

b) Covering plate

Figure 5. Recess elements for column shoes

The recess former includes screw, hole spacer, and washer. It is a reusable product made from steel. The covering plate is welded to the column shoe to create the recess area in the formwork. As it remains inside the column after grouting, it is a single-use item. Please inform related sales representative of your requirements for recess formers and covering plates.

Alternatively, if customers prefer to create the required recess themselves using wood, EPS, or other materials, the necessary dimensions for the recess elements corresponding to the column shoe size are shown in Table 10 and Table 11.

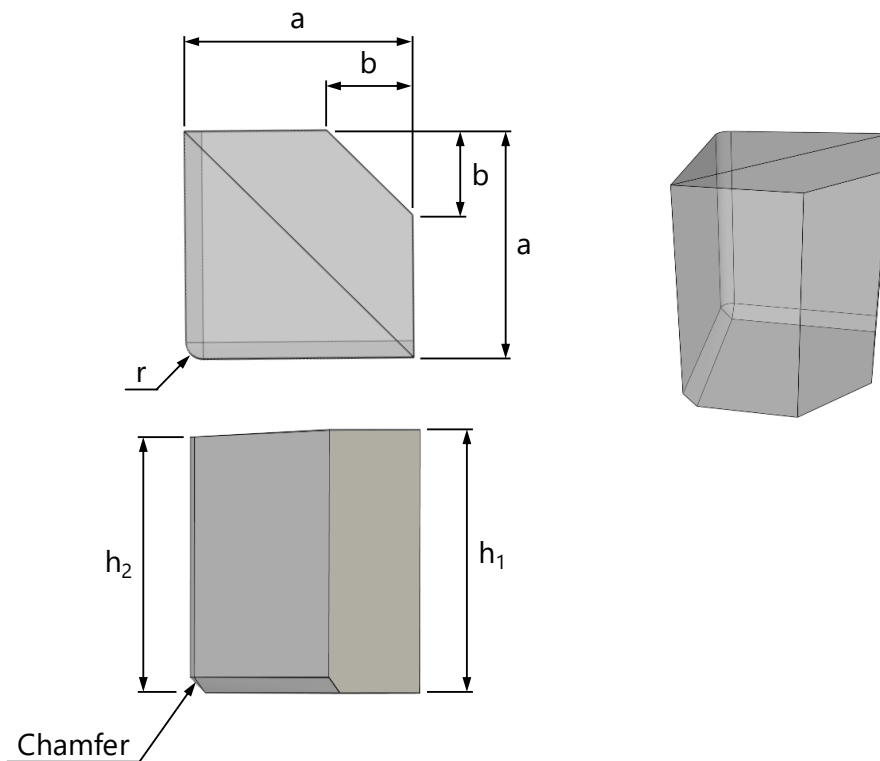







Figure 6. Dimension markings of self-made recess element for corner shoes

Table 10. Self-made recess element dimensions for N3 type corner column shoes

RPK-N3	a [mm]	b [mm]	r [mm]	h ₁ [mm]	h ₂ [mm]	Chamfer [mm] × [mm]	Color
M16	78	15	8	100	90	10 × 10	
M20	81	15	8	100	90	10 × 10	
M24	90	15	10	120	110	15 × 15	
M30	93	15	20	130	120	15 × 15	
M39	117	15	20	180	170	25 × 25	

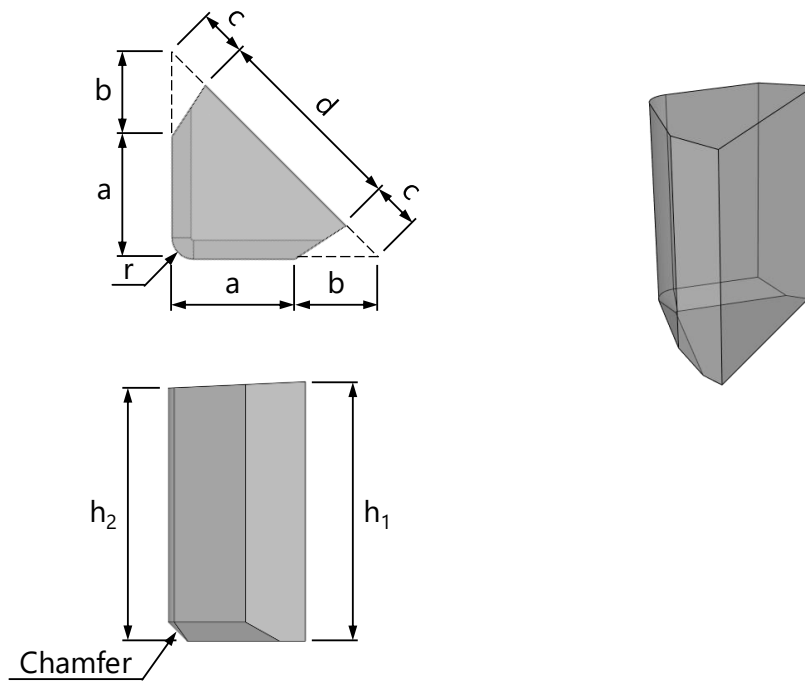

Figure 7. Dimension markings of self-made recess element for middle shoes

Table 11. Self-made recess element dimensions for N3 type middle column shoes

RPK-N3	a [mm]	b [mm]	c [mm]	d [mm]	r [mm]	h ₁ [mm]	h ₂ [mm]	Chamfer [mm] × [mm]	Color
M16	80	50	20	144	8	102	94	10 × 10	Yellow
M20	85	50	20	151	8	100	91	10 × 10	Blue
M24	95	55	25	162	10	120	111	10 × 10	Grey
M30	100	60	35	156	20	130	120	10 × 10	Green
M39	120	80	45	193	22	210	198	15 × 15	Orange

6.2.2. Installation accessories for shoe positioning

RSTEEL® provides steel plates for positioning column shoes in precast columns. These template plates are manufactured according to the client's specified column dimensions and requirements. Examples of rectangular and circular steel plates are displayed below in the image.

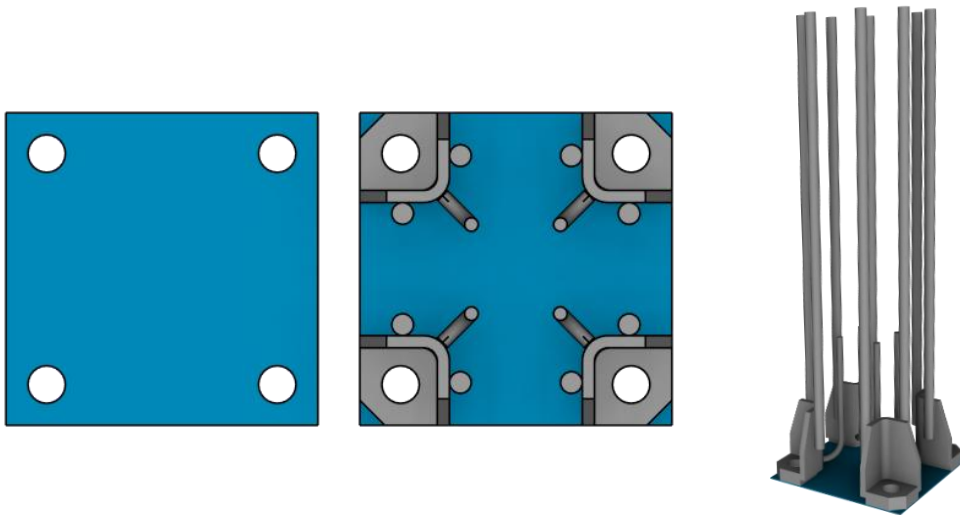

Figure 8. Rectangular steel plate

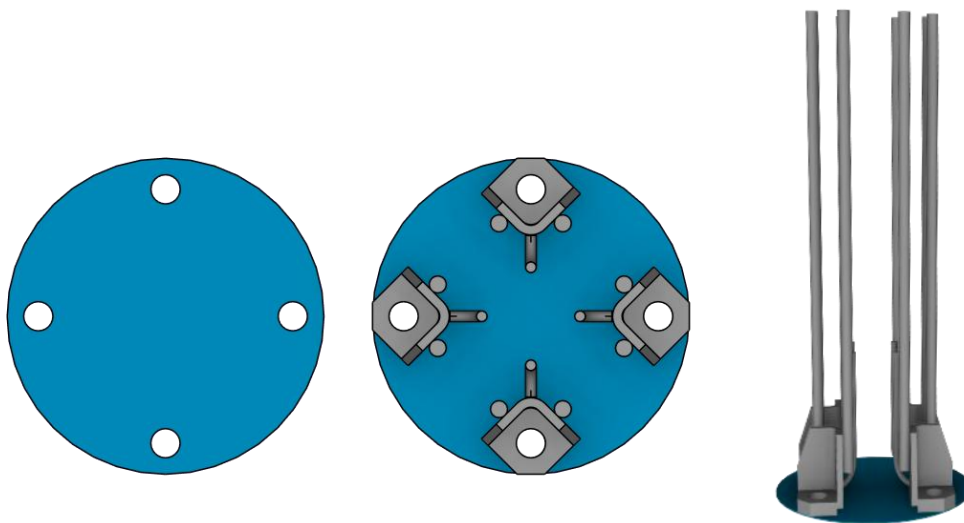

Figure 9. Circular steel plate

The minimum column dimensions for column shoes are provided in Table 6. If the project requires smaller column sizes than those listed in Table 6, column shoes can be welded to the template plate, and tail rebars can be welded together to maintain the product's resistance. For any design-related inquiries, please contact our technical department at technical@rsteel.eu. Additionally, please inform your sales representative regarding your template plate requests.

TECHNICAL MANUAL REVISIONS

23.08.2022 (FA, JK)

- Shoe types and generations separated into own technical manuals
- New graphical layout

04.09.2022 (FA)

- Additional information about stirrups added to Table 7

19.12.2022 (FA)

- Column shoe dimension figure updated and Table 2 corrected

16.08.2024 (FA)

- EXC 3 welding class added
- Table 4: Lever arm (t_R) values recalculated according to ISO 4032 nuts dimensions; shear ($V_{Rd,u}$) values updated
- Table 7: L_0 values are updated
- Section 6 is extended

04.09.2025 (AV)

- Minor text changes

21.04.2026 (AV)

- Nuts tightening explanation updated
- Self-made recess element dimensions updated

DESIGN TOOLS

RSTEEL® Design Tool was created to facilitate the work of designers and offer the best and most transparent design process on the market. The free and fully cloud-based software guarantees seamless workflow within the design organization, as well as continuous support and updates.

rsteel-design.com

DESIGN COMPONENTS

We have created design components for Tekla as well as Revit and AutoCAD. More products will be created, and existing products will receive steady updates and fixes when needed.

warehouse.tekla.com/#/organization/u7be79e90-ace8-46ca-a26c-849a5dc4c283

proplib.com/rsteel

SALES AND TECHNICAL SUPPORT

Our excellent sales and support team will assist you with all your challenges and questions.

rsteel.eu/contact-us/

DOCUMENTATION

All our products have been tested and have all necessary approvals and markings. You can find all related information on each products page.

rsteel.eu/products/